

4

3

2

1

B

B

A

A

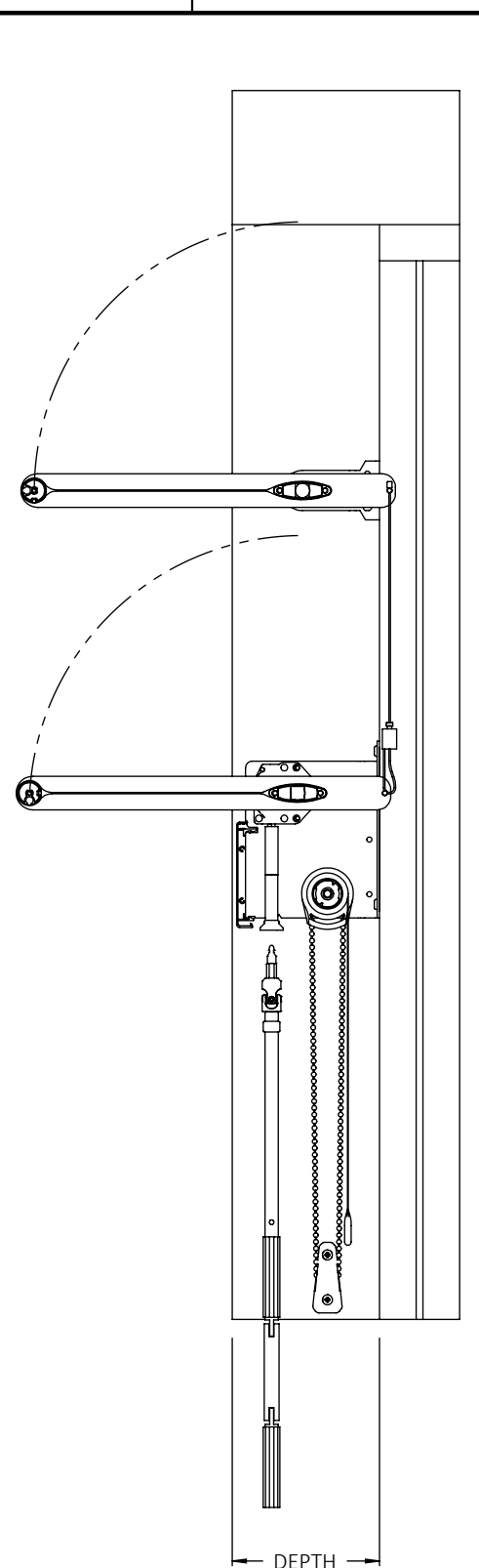
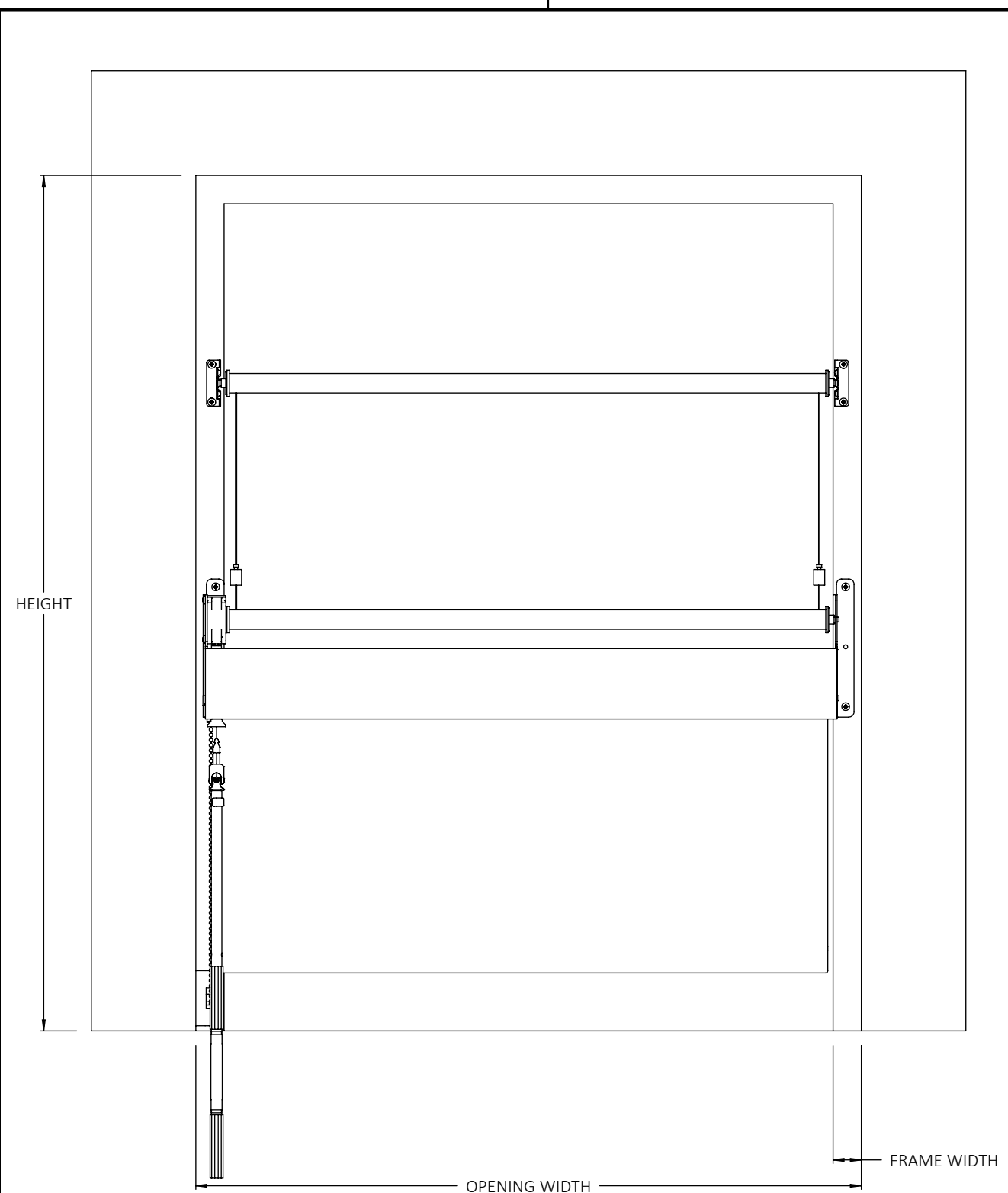

LOCATION/ ORIENTATION	QTY	OPENING WIDTH	FRAME WIDTH	HEIGHT	DEPTH	HEIGHT ABOVE FLOOR

FACE MOUNT

INSIDE MOUNT

COMMENTS:

FABRIC: _____

PATTERN #: _____ COLOR: _____ OPENNESS %: _____

PROJECT: _____

SIGNATURE: _____

- NOTES:
1. MEASURE WIDTH OF OPENING AT EXACT LOCATION WHERE BRACKETS WILL BE INSTALLED
 2. NUMBER OF LIGHTSHELVES _____
 3. SHADE MAY BE MOUNTED ON THE JAMB (*INSIDE MOUNT*) OR FACE OF FRAME (*FACE MOUNT*)
 4. PLEASE SPECIFY DEPTH OF LIGHTSHELF _____ (*DEFAULT IS 16"*)
 5. FOR OTHER WINDOW CONFIGURATIONS, SEE PAGE 2



WILLIAMSPORT, PA
570.651.5105
WWW.INDOOR-SKY.COM

UNLESS OTHERWISE SPECIFIED:
DIMENSIONS ARE IN INCHES

TOLERANCES:
ANGULAR: ±.5°
FRACTIONAL: ± ¹/₁₆
X ± .015
XX ± .010"
XXX ± .005"

TITLE:
L-SERIES TEAR SHEET

DRAWN BY	M.HORNER	SCALE: 1:6	DWG. NO.	REV	SHEET 1 OF 2
----------	----------	------------	----------	-----	--------------

4

3

2

1

4

3

2

1

B

B

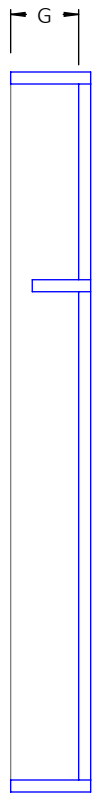
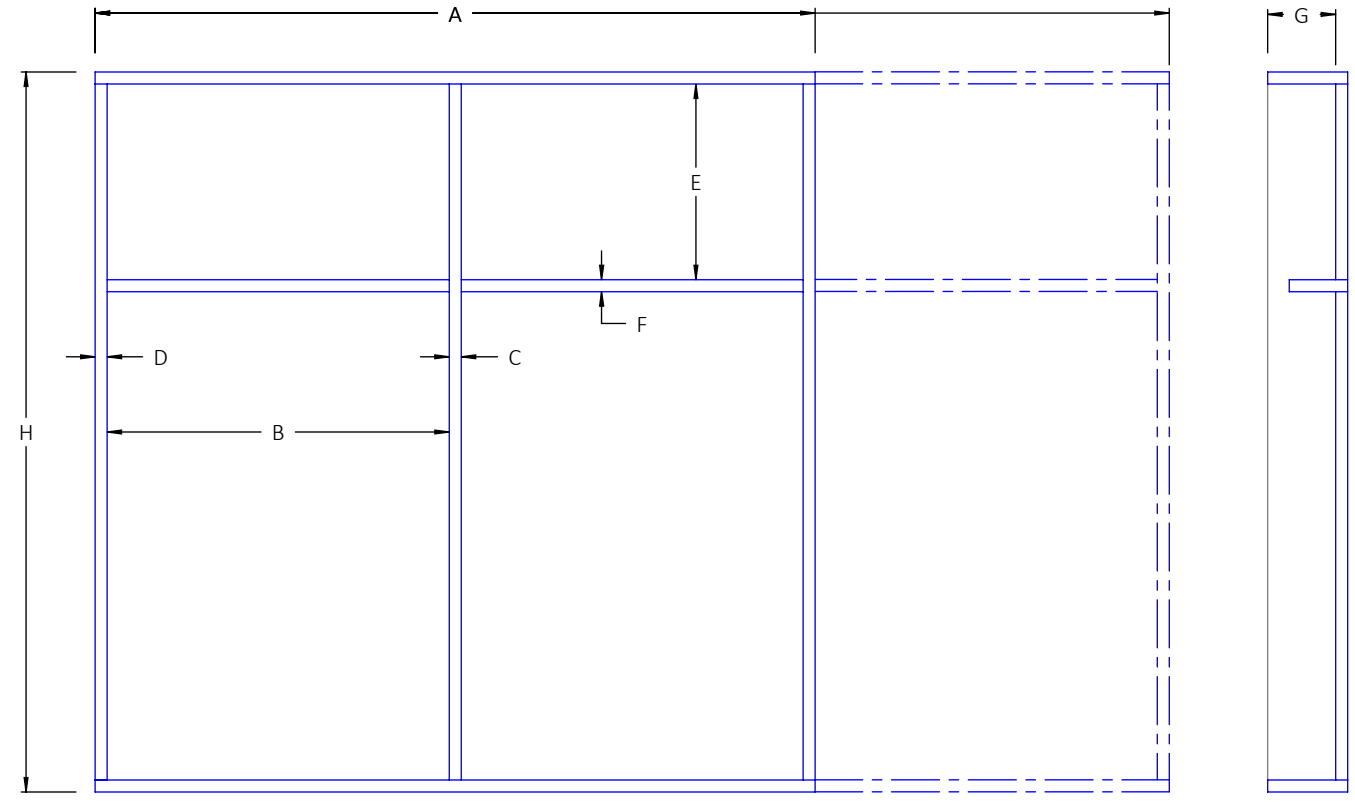
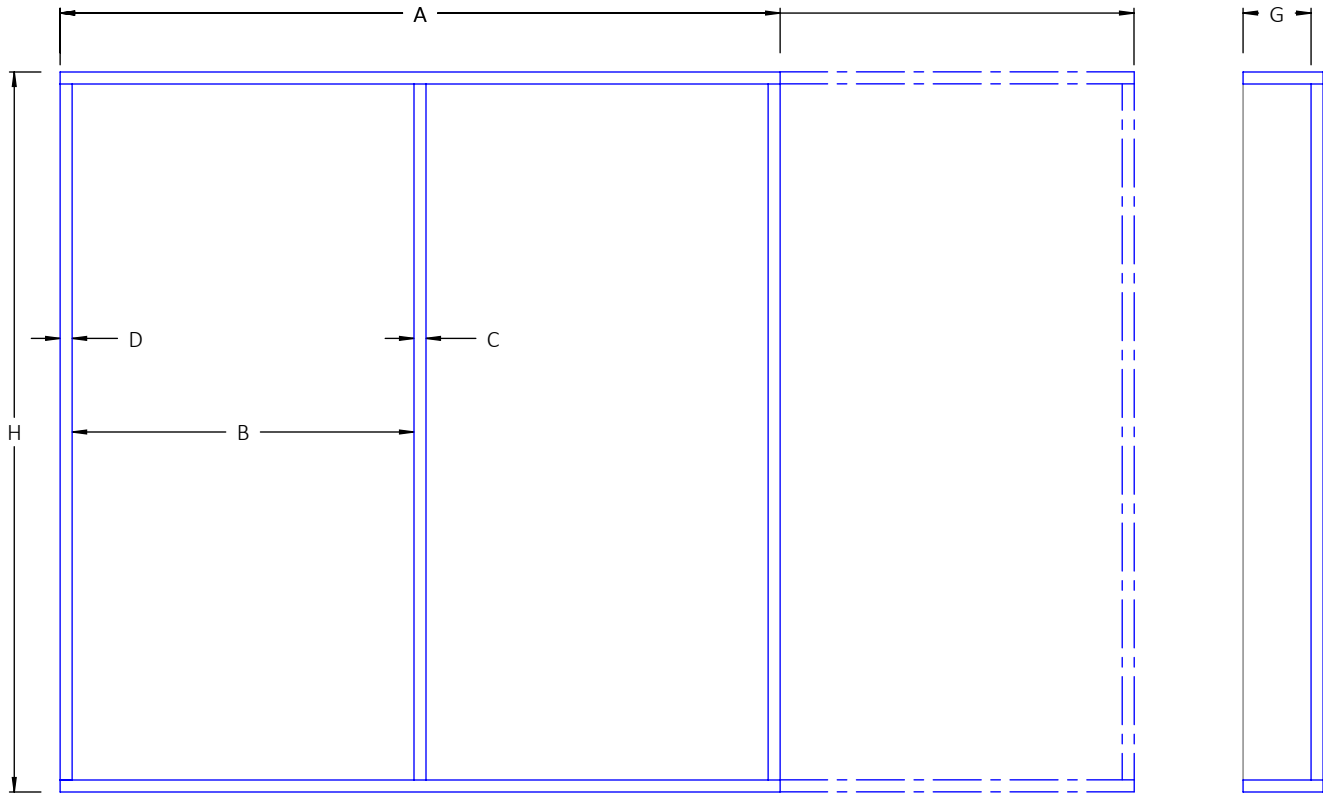

(FLOOR)

A

A

		A	B	C	D	E	F	G	H	I
LOCATION/ ORIENTATION	QTY	OPENING WIDTH	INSIDE MULLION WIDTH	MULLION THICKNESS	FRAME THICKNESS	CLERESTORY HEIGHT	TRANSOM THICKNESS	JAMB DEPTH	HEIGHT	HEIGHT ABOVE FLOOR



WILLIAMSPORT, PA
570.651.5105
WWW.INDOOR-SKY.COM

UNLESS OTHERWISE SPECIFIED:
DIMENSIONS ARE IN INCHES

TOLERANCES:
ANGULAR: ±.5°
FRACTIONAL: ± 1/16
X ± .015
XX ± .010"
XXX ± .005"

TITLE:
L-SERIES TEAR SHEET

SIZE B	DWG. NO.	REV
------------------	----------	-----

DRAWN BY	M.HORNER	SCALE: 1:6	SHEET 2 OF 2
----------	----------	------------	--------------

4

3

2

1